



## Air Quality Permits – Applicant and DEQ Responsibilities

This document is designed to provide applicants a basic understanding of DEQ's air quality permitting process, it also **describes applicant's responsibilities and how DEQ will interact with applicants** throughout the permitting process. It is intended to be brief but convey a general overview of the Idaho air quality permitting process. [Application forms, guidance and checklists](#) are made available on [DEQ's Web site](#) and include more detailed directions than does this general discussion. Links are provided to this web page throughout this document (links are presented with underlined text).

When a facility submits an application there should be no question about what is required. No unanswered questions should remain regarding what emission inventory must be submitted, what type of ambient impact analysis must be included, what the regulatory requirements are, or how all of this must be included in the application. If an application does not contain the appropriate information it is very likely it will be determined incomplete or denied. For these reasons, DEQ highly recommends that facilities request a meeting or teleconference with DEQ at least two weeks prior to submitting an application to discuss the applicant's responsibilities. Applicants should contact the Air Quality Permit Hotline (1-877-573-7648) to schedule a meeting.

### Brief Summary of Applicant's Responsibilities

- Contact DEQ for a pre-application meeting (1-877-573-7648)
- Conduct, and thoroughly document, a review of all applicable rules and regulations.
- Conduct, and thoroughly document, all necessary ambient impact assessments including any necessary air pollution dispersion modeling (Does not apply to Tier I permits).
- Conduct, and thoroughly document, all necessary emission inventories.
- The facilities responsible official must certify, based on information and belief formed after a reasonable inquiry, that the statements and information in the application are true, accurate, and complete.
- Submit a \$1,000 application fee along with all applications for a permit to construct (No application fees are required for Tier I or Tier II operating permits).
- Pay the appropriate permit to construct and Tier II operating permit processing fee according to the invoice issued by DEQ.
- Pay annual registration fees for issued Tier I permits according to the invoice issued by DEQ.
- **Two hard copies of the application and a compact disc (CD) with a PDF version of the application are required to be submitted.**

Applications must be mailed to:

Air Quality Program Office - Application Processing  
Department of Environmental Quality  
1410 N. Hilton  
Boise, ID 83706-1255

DEQ will work with applicants prior to submitting applications to aid in providing an understanding of the applicant's responsibility. However, once the application is submitted it is expected that all the necessary information is included in the application. **It is emphasized that it is the applicant's responsibility to satisfy all technical and regulatory requirements, and that DEQ will help the applicant understand what those requirements are prior to the application being submitted but that DEQ will not perform the required technical or regulatory analysis on the applicant's behalf.**

If you need an air quality permit, the application must include appropriate application forms provided by DEQ. Alternate means of providing information in the forms must be approved in advance by DEQ. DEQ has developed detailed [guidance documents and checklists](#) to aid applicants in submitting a successful application. DEQ also has implemented an air quality permitting Hot Line (-877-573-7648) so that applicants may ask permitting questions directly to a DEQ Permit Writer and schedule a pre-application meeting.

### **Types of Air Quality Permits**

In Idaho there are 3 types of air permits: Permits to Construct, Tier I Operating Permits, and Tier II Operating Permits.

#### **Permits to Construct (PTC)**

The permit to construct program is commonly referred to as the New Source Review program and is required for new or modified sources (unless exempt). Permits to Construct do not expire unless construction has not begun within two years of its issue date or if construction is suspended for one year.

- To determine if you are exempt from the need to obtain a permit to construct, see the [exemption guidance](#).
- Permits by rule are available for [Dairies](#) and [Rock Crushers](#). Registration requirements include a \$250 fee for Rock Crushers.
- General Permits are under development for Hot Mix Asphalt Plants, Concrete Batch Plants, Spray Painting – Call DEQ to discuss availability (1-877-573-7648).
- [15 day pre-permit construction approval](#) is available for those who thoroughly understand the permitting process or those who use consultants whom have a thorough understanding of air permitting. 15-day pre-permit approval is not generally recommended, it is intended for use by those whom have a thorough understanding of the permitting process and do not need assistance from DEQ to understand the application requirements.
- PTC applications require [\\$1,000 PTC application fee](#).
- A [PTC processing fee applies](#) (this is in addition to the application fee). The processing fee depends on the type of permit issued and on the amount of emissions which are permitted. Processing fees range from \$500 to \$5,000 for permitted emissions less than 100 tons per year, and from \$7,500 to \$10,000 for permitted emissions greater than 100 tons per year. Processing fees are not required for permits by rule (Dairies and Rock Crushers; a \$250 registration fee applies for Rock Crusher).

The Permit to Construct application processing schedule is: ([IDAPA 58.01.01.209](#))

- Up to 30 days to review the application for completeness; then
- Up to 60 days to prepare a permit if the application is determined complete; then
- Up to 10 days for the applicant to review a draft permit if a draft is requested; then
- 30 days –public comment when required; then
- 15 days – prepare response to comments received unless the Director determines additional time is necessary.

DEQ will process applications as expeditiously as resource allow and is striving to achieve an average processing time of 99 days. Applications which do not include all of the necessary information consume more resources and take more time to process than those applications which do include all the necessary information.

### *Tier II Operating Permits*

Tier II Operating permits are issued to facilities when DEQ has determined that a facility needs an air permit to comply with applicable rules, or when an applicant has specifically requested one. The most common type of Tier II operating permit that DEQ issues are those which the applicant have requested in order to establish synthetic minor emission limits. If you are commencing construction of a new source or modifying an existing source it is a PTC that you will need, not a Tier II operating permit. Tier II Operating Permits expire within 5 years; facilities must submit an application to renew the permit in advance of it's expiring (assuming they wish to maintain a valid permit to operate). Processing schedules are the same as those for a permit to construct.

### *Tier I Operating Permits*

Tier I Operating permits (also known as Title V permits) are [required for all major sources of air pollution](#). Tier I Operating permits are required for major sources even if the facility already has a PTC or Tier II permit. Tier I permits expire within 5 years. Facilities must submit an application to renew Tier I permits at least six months before, but no earlier than 18 months before, the expiration date.

## **Applicant Responsibility**

**For all permit types it is the applicant's responsibility to satisfy all of the requirements of the Rules by developing an application that is complete and self sufficient in providing all of the necessary information.** Once an application is submitted DEQ will not solicit the applicant to supply the necessary information which has been omitted, if the application is lacking necessary information the application will be determined incomplete or denied. The applicant may resubmit upon generating an application with all the necessary information. In the case of a permit to construct denial it should be noted that \$1,000 application fee is required for each application, and that the fee is not transferable or refundable. If a permit to construct application is denied and a new application is submitted a \$1,000 application fee is required to be submitted along with that application. In summary, the application process mandates that air permit applications include all the necessary information to satisfy the Rules; DEQ will not perform the required technical or regulatory analysis on the applicant's behalf nor will DEQ solicit the applicant for the necessary information after the application has been submitted – the application will be determined incomplete or denied.

DEQ's goal is to establish a permitting process that when followed results in the facility submitting a complete application to begin with. To accomplish this goal DEQ highly recommends that facilities request a meeting or teleconference with DEQ at least two weeks prior to submitting an application. Applicants should contact the Air Quality Permit Hotline (1-877-573-7648) to schedule a meeting. The intent of the meeting is to assure that the applicant understands the application process, and to have a detailed discussion on the methods that the applicant must use to sufficiently document emission inventories, ambient impact assessments (not applicable to Tier I permits), and the regulatory analyses that must be conducted. [When air pollutant dispersion modeling is required](#) it is also highly recommended that a written modeling protocol be submitted to DEQ for approval prior to submitting the application. Pre-application meetings should include the DEQ Permit Coordinator, the DEQ Permit Writer who will be assigned the project, and DEQ Modeler who will review the modeling submissions. DEQ has also developed application [forms, guidance and checklists](#) which DEQ recommends applicants use because they are designed to help the applicant to submit a complete application. Copies of completed checklists must be submitted with all applications.

Applications for any type of air permit (PTC, Tier II, and Tier I) have general application requirements in common. The general application requirements for PTC and Tier II Operating permits are identical. Tier I permit general application requirements are identical with the exception that an ambient impact assessment (i.e. modeling) is not required.

### Applications Must be Supported by the Appropriate Analyses

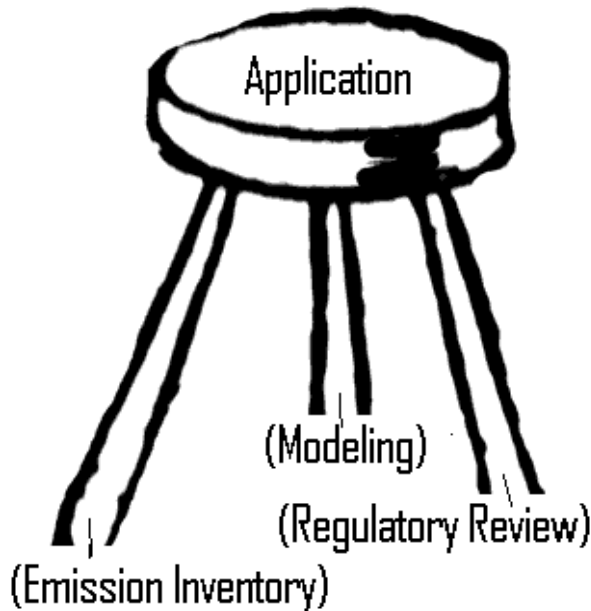

(Note - Tier I applications don't require modeling)

### Reasons for Incomplete or Denied Applications

Applications which are determined incomplete or that are denied can be attributed to the applicant not fulfilling one of the three generally applicable application requirements. Either the emission inventory, ambient impact assessment (modeling-when required), or the regulatory review were not addressed, were inaccurate, were insufficiently documented, or failed to show compliance with applicable regulations. Meeting with

DEQ prior to submitting applications can greatly increase the likelihood the application is complete.

Following is a brief discussion of typical deficiencies of the three generally applicable application requirements which are: emission inventory; modeling; and regulatory review.

### *Emission Inventory*

Often applicants do not submit emission inventories sufficient to demonstrate compliance with applicable regulations. For instance if a regulatory emission standard is expressed in specific units (i.e. grains per dry standard cubic foot, pounds per ton of throughput, etc.) then an emission inventory must be provided in the applicable units, and it must demonstrate the facility is capable of complying with the standard. Before conducting an emission inventory the applicant must have a clear understanding of what regulatory requirement is being satisfied through the calculations.

Emission inventories are often not sufficiently documented. Documentation must consist of showing calculations, stating all assumptions, and providing documentation of the emission factors which were used. If the documents from which the emissions factors are obtained are not readily available to DEQ those documents must be included in the application.



Documentation must be sufficient so that DEQ can verify the validity of the emission inventory. For instance if source tests on similar facilities are the basis of the emissions inventory then the applicant must describe why emissions from the two facilities are similar, and provide the source test report upon which the emission inventory is based (what testing methods were used, what was the operating status of the emissions units that were being tested, etc.). Applicants are also expected to use the best available information.

Emission inventories conducted to be used in air pollution dispersion modeling analyses must match the input to the computer model. It would seem that this could go without saying, but it is surprising the number applications which are received where the calculations do not match the input to the computer model.

Applicants should contact the Air Quality Permit Hotline (1-877-573-7648) to discuss emission inventory requirements or to schedule a meeting.

A few common emission inventory deficiencies are:

- Calculations are not sufficiently documented.
- Emission factors are not sufficiently documented or references are absent.

- When computer spreadsheets are used electronic copies of the spreadsheets are not submitted.
- Emission estimates do not match input to air pollution dispersion modeling.
- Emission inventories do not address all regulated air pollutants.

### *Modeling*

Applicants seeking to obtain a permit to construct must demonstrate to DEQ's satisfaction that ambient standards and toxic air pollutant increments will be protected. In addition to requesting a pre-application meeting DEQ also strongly recommends that the applicant develop and submit for DEQ approval a written modeling protocol prior to submitting the application. DEQ has developed a [Modeling Guideline](#), and Modeling Protocol Check List (Appendix D of the Modeling Guideline) to assist applicants in submitting a complete application.

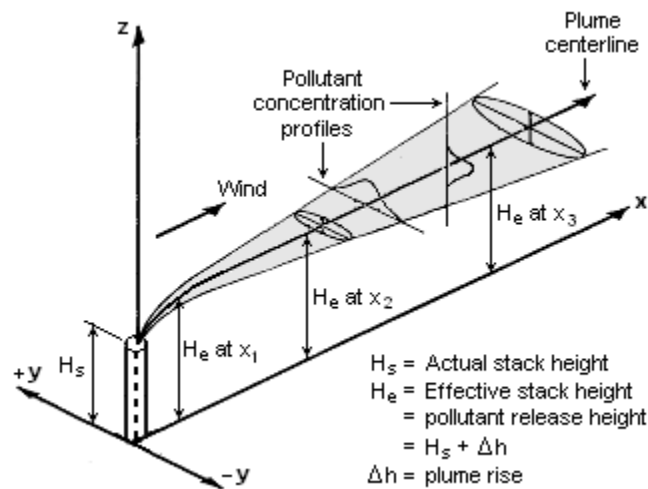

A few common modeling deficiencies are:

- The result of an applicant not obtaining an approved modeling protocol which addresses all modeling issues including which model and background concentrations to use.
- Emission calculations not matching input to the model.
- Incorrectly selecting how an emission unit should be modeled (point, volume, area) and not documenting sufficiently why an emission unit was modeled the way it was.
- Modeling results that do not demonstrate compliance.
- Incorrectly establishing the ambient air boundary.
- Providing insufficient documentation/justification of release parameters (stack temperatures and flow velocities).

In summary, it is strongly recommended that an applicant meet (or teleconference) with DEQ, and that modeling protocol be prepared for DEQ approval, prior to submitting an

application. During the meeting (or teleconference) it can be decided if modeling is required. Applicants can call DEQ's permitting Hotline (1-877-573-7648) with general modeling questions or to schedule a teleconference. Specific modeling questions should be directed to DEQ's Modeling Group at 208-373-0502. DEQ's Permitting Hotline is staffed by Permit Writers who have a general understanding of modeling but are not experts on modeling requirements; detailed modeling questions should be directed to the Modeling Group.

### ***Regulatory Review***

It is the applicant's responsibility to identify and demonstrate compliance with all applicable air quality rules and regulations. If an applicant does not know which rules or regulations apply then it is virtually impossible to submit an application which demonstrates compliance. Applications that have been submitted which do not identify and demonstrate compliance with all applicable requirements will be determined incomplete or denied. Again, DEQ strongly recommends that all applicant's meet (or teleconference) with DEQ prior to submitting an application. DEQ will assist in identifying the applicable requirements that the applicant must include in the application but will not perform the required technical or regulatory analysis on the applicant's behalf.

The most commonly applicable rules and regulations are:

Rules for the Control of Air Pollution in Idaho – [IDAPA 58.01.01](#)

New Source Performance Standards (NSPS) – [40 CFR 60](#)

DEQ recommends applicants to follow the underlined NSPS link to review the regulations to determine if a NSPS affected emission unit is part of their proposal. Examples of NSPS affected emissions units include internal combustion engines, boilers, turbines, etc.

National Emission Standards for Hazardous Air Pollutants (NESHAP) – [40 CFR 61 & 63](#)

DEQ recommends applicants to follow the underlined link to review the regulations to determine if a NESHAP affected emission unit is part of their proposal. Examples of affected emission units include solvent cleaning operations, industrial cooling towers, paint stripping and miscellaneous surface coating. [EPA has a web page dedicated to NESHAP](#) that should be useful to applicants.

DEQ has developed an application form for NSPS and NESHAP requirements ([Form FRA](#)). These forms are designed to provide DEQ with all the necessary NSPS and NESHAP information.

Compliance assurance monitoring (CAM) – [40 CFR 64](#)

DEQ has developed an application form for the CAM requirements ([Form CAM](#)).

A few very common regulatory analysis deficiencies are:

- Applicants omit applicable Rules/Regulations from their application
- Applicants do not conduct a detailed review of the Rules/Regulations that are applicable
- Applicants do not document compliance with the Rules/Regulations that are applicable
- Applicants do not appropriately review emissions for compliance with state regulated toxic air pollutants (see DEQ's [Toxic Air Pollutant Preconstruction Compliance Checklist](#))